



METAL FORM MANUFACTURING CO., INC  
 5960 WEST WASHINGTON STREET  
 PHOENIX, ARIZONA 85043  
 TELEPHONE: 602-233-1211 FAX: 602-233-2033  
 WEBSITE ADDRESS: WWW.MFMCA.COM

# Model MFL-30CD Fabricated Combination Louver 6" Deep Stationary / Adjustable Blade

## Specifications

- Frame:** 18ga. galvanized steel channel frame.
- Blades:** 18ga. galvanized steel stationary.  
18ga. galvanized steel adjustable.
- Bearings:** Molded nylon.
- Axles:** 7/16" hex plated steel.
- Linkage:** Heavy duty plated steel concealed in frame.
- Screen:** 1/2" x 1/2" x 19ga. galvanized steel..
- Finish:** Standard mill.
- Minimum size:** 12"w x 14"h.
- Maximum size:** 60"w x 96"h.  
Multiple section - unlimited size.

## Options

- Flanged frame.
- Blade edge seals.
- Stainless steel side seals.
- Sill extension.
- Sleeves.
- Sub frame (requires flanged louver).
- Screens - Many variations of screens are available , consult factory.
- Finishes -Many types of finishes are available, consult factory.
- Other options are available, consult factory.

## Notes

1. Width x height are nominal opening dimensions. Unless specified otherwise, units will be constructed 1/4" undersize.
2. Metal Form reserves the right to improve design or change specifications at any time.

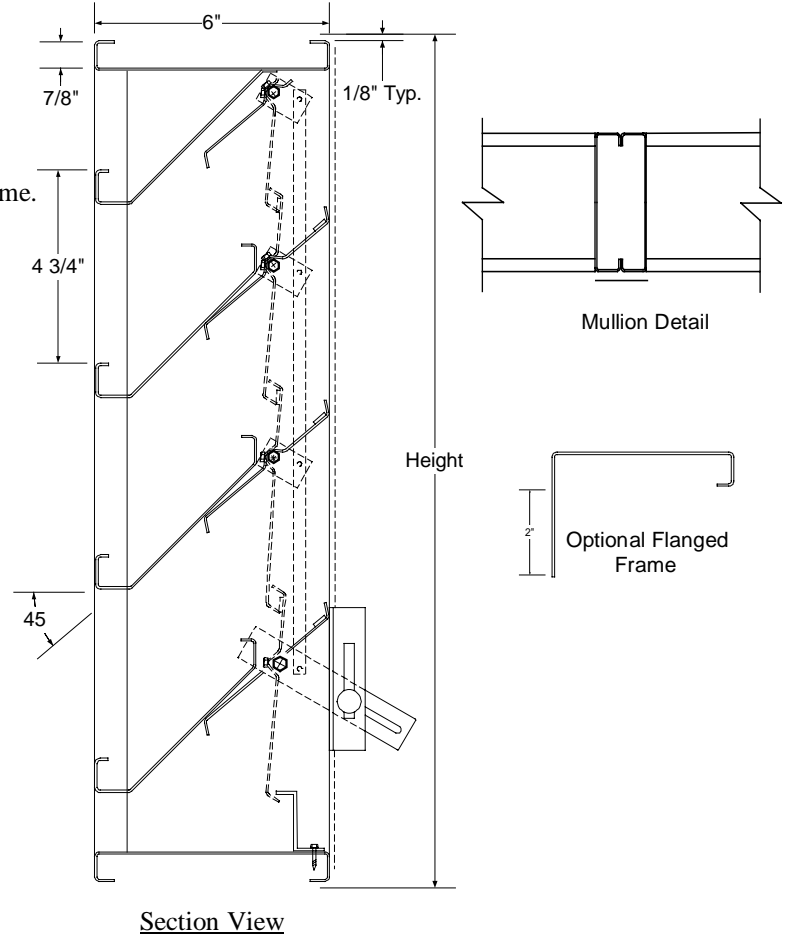

Tag	Qty.	Width	Height	No. of Panels (W x H)	Options	Finishes/Specify	Remarks

**Project:** \_\_\_\_\_  
**Architect:** \_\_\_\_\_  
**Engineer:** \_\_\_\_\_  
**Contractor:** \_\_\_\_\_